



EVO4 Data Logger

USER GUIDE



Made in Italy



AiM Srl.
Via Cavalcanti, 8
20063 Cernusco S/N (MI)
Italia
Tel. (+39) 02.9290571

www.aim-sportline.com



EVO4 Data Logger

- 04 INTRODUCTION
- 08 GETTING STARTED
- 12 GENERAL INFORMATION
- 16 LINKS, SENSORS AND CONFIGURATIONS
- 20 ECU CONNECTIONS
- 22 THE RPM CHANNEL
- 28 THE SPEED CHANNEL
- 32 ANALOG INPUTS
- 36 GPS
- 38 GPS MANAGER SOFTWARE
- 48 DATA SHEET EVO4



Thanks.

Firstly, we would like to thank you for choosing the EVO4 Data Logging System as the tool for improving your race craft setup and on-track performance.

The EVO4 system, with its advanced expansion and sampling capabilities, gives you the flexibility of recording data from a variety of sensors and sources.

With integrated GPS, a built-in three axis accelerometer, and direct connectivity to hundreds of aftermarket and factory ECUs, the EVO4 is an exceptional data platform.

As you begin working with your new EVO4 system, we are sure questions will come up. If they do, please let us know...info@aim-sportline.com. We are all too happy to help!

One more thing before digging into your new data system...we are constantly working on bettering our software and firmware, so please be sure to check the website periodically for any applicable software or firmware updates...www.aim-sportline.com



What is EVO4?

EVO4 is a complete, compact and expandable data logger, suitable for installation on both car and motorcycle.

What data reads?

EVO4 acquires:

5 analog inputs, at a configurable frequency from 1 to 1000 Hz per channel. These signals can be: 0-5 Volt, 0-500 mV, 0-50mV, thermocouples K.

2 digital inputs, suitable to receive signals from speed sensors.

1 RPM input, suitable to receive signals from low voltage of the coil or square wave 0-12 Volts.

Data coming from internal triaxial accelerometer.

Data from the internal GPS with external antenna.

Data coming from the engine control unit (ECU). There are three hardware protocols available: CAN, RS232 and Linea K.

Hundreds of ECU are fully supported.

The lap time transmitted from the infrared receiver.

The internal temperature of the system.

What is the maximum frequency of acquisition possible?

It is possible to acquire signals at a maximum total frequency of 5000 samples per second (i.e. 5000 Hz).

How much memory is available?

EVO4 has 16 MB of non-volatile memory capable of recording more than 4 hours of data at a total frequency of 500 samples per second.

To what purpose you can use the GPS?

The integrated GPS is useful for different purposes.

Lap time calculation:

A large database of world tracks are available.

The coordinates of the finish line are available for many world tracks. When turned on, EVO4 recognizes which track you are at and uses the coordinates to calculate the lap time with high precision.

Measurement of the speed of the vehicle:

In contrast to the measurement of the wheel speed, the speed measure based on GPS signals is not affected by the variation of the size of the wheel (due to the centrifugal force, the crushing and, in case of bikes, the inclination of the bike itself) and is thus more precise.

Analysis of the trajectories:

GPS receiver is an important tool to properly calculate the trajectory at every single lap and then to compare the different driving strategies.

Which displays can be connected?

EVO4 can be connected to the following dashes:

GDash

MXL Dash

Formula Steering Wheel

GT steering wheel 32/35

Which expansion modules are available?

EVO4 can be connected to the following expansion modules (max.8)

Channel Expansion: 4 additional analog channels 0-5 Volt. You can add up to 7 channel expansion.

TCHub: 4 thermocouple channels.

LCU-One Lambda Controller

Memory Module: memory module with additional SD card.

SmartyCam: the powerful camera with data overlay.

EVO4

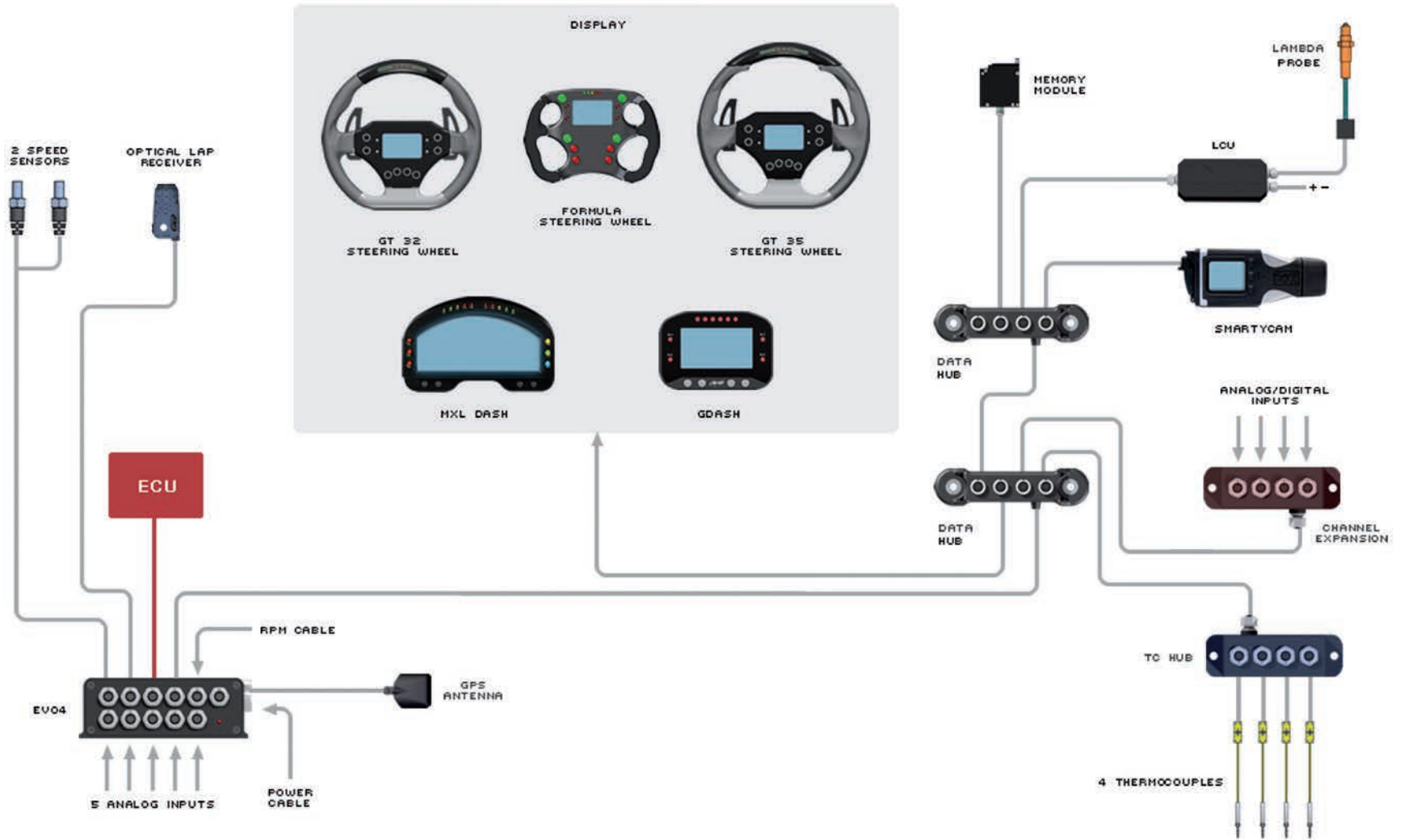

EVO4

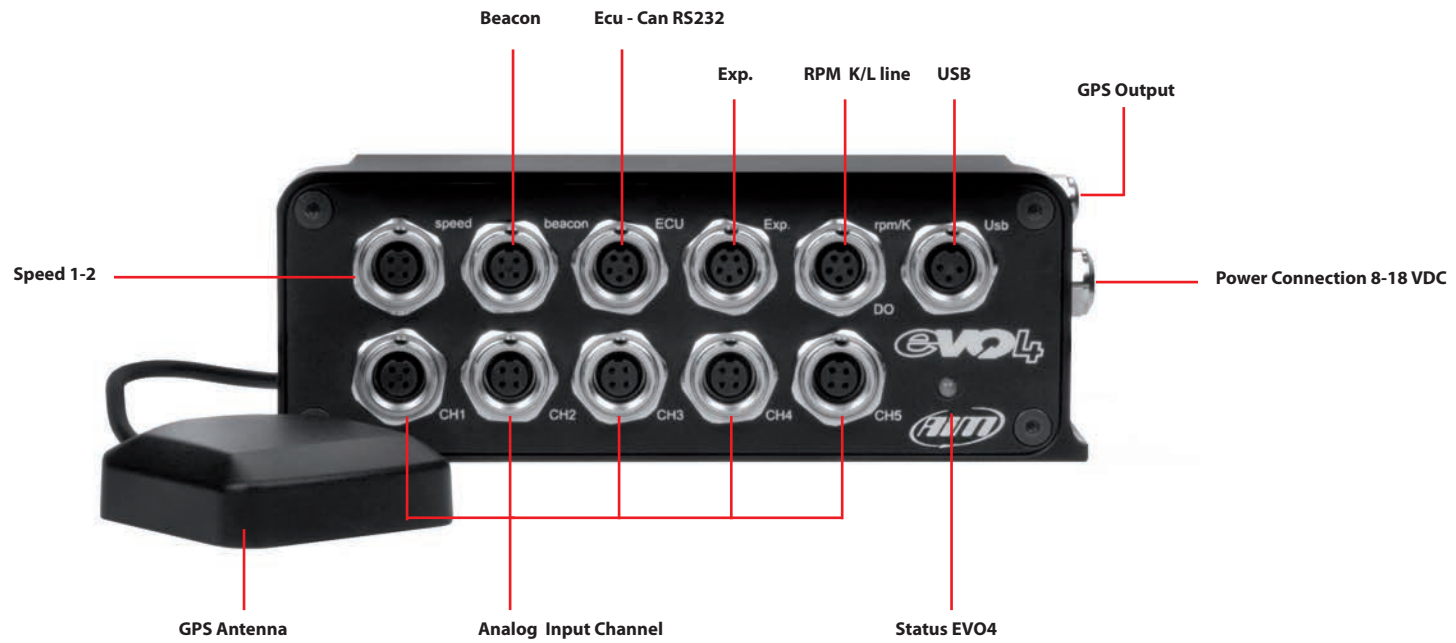

EVO4 Kit includes.

- 1** - EVO4
- 2** - GPS Antenna
- 3** - RPM cable + K Line + Dig. out
- 4** - Connection cable to ECU CAN/RS232
- 5** - USB cable for connection to PC
- 6** - Software RaceStudio2 CD



Power.

Power is provided by connecting the appropriate cable to the battery of your vehicle. It is not necessary to use special attention, because there is a stabilizer that regulates the internal power supply used by the system.

So you can connect EVO4 without any problem to a NOT stabilized power source from 8 to 24 Volts. Even shutting down the system does not require special attention: when the power is turned off, a small battery in the system keeps the internal power supply on for a few seconds in order to properly close the internal data files.

If your power is too spiky, an external power filter (code **X60FLCEVO4**), is available.

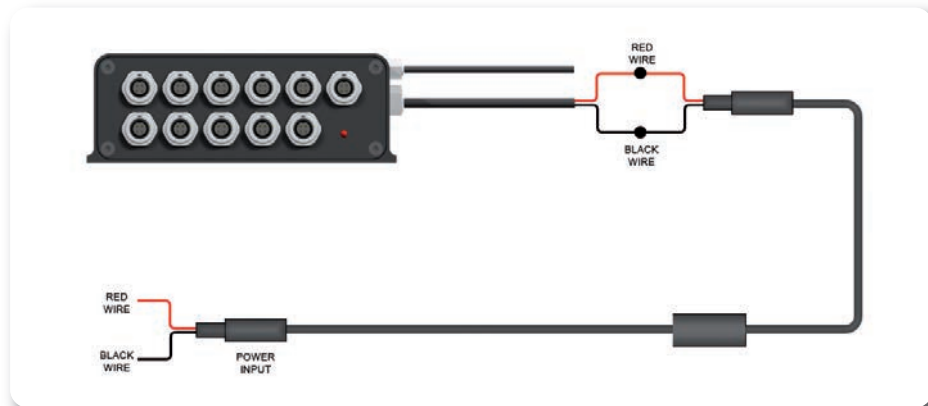

Wiring diagram of external filter X60FLCEVO4



Data Recording.

EVO4 is equipped with a 16 MB circular memory *, capable of recording 8 million samples.

The test length that can be recorded depends on the sampling frequency (i.e. how many channels per second are recorded).

For example, in case your acquisition has a global frequency of 500 Hz, which is fairly common, the system can record almost 4 hours of testing.

If you require larger memory, the external Memory Module is available: it can manage a SD Card up to 16 Gygabyte SD and can provide virtually unlimited recording capability.



* "Circular buffer" means that once it reaches saturation, the oldest data are overwritten by the most recent

■ The LED on the front shows:

- 1 Hz blink : Stand-by status
- Solid state : Data recording in progress
- 3 Hz blink: system configuration problems
- Flashing in alternating colors: firmware upgrade in progress



Status LED

Start/Stop Recording.

EVO4 starts recording when one of the following situations persist for more than three seconds:

- RPMs over 500 rpm threshold
- Speed over 10 km / h

Thanks to a pre-buffers, EVO4 records also the three seconds before the engine starts.

Data Download.

After activating the Aim software Race Studio2, the data are transmitted to the PC using the USB cable supplied with the product.

If you have recorded the test on the Memory Module, you can directly insert the SD card into your PC.

At the end of the data download, you can delete the data in EVO4 or leave them in memory, to eventually download them to another PC.



Links, Sensors and Configurations.

Here are the different EVO4 connection possibilities:

- To ECU
- To RPM signal
- To speed signal
- To analog inputs
- To expansions
- To the optical lap time receiver

When connecting EVO4 to a sensor, to ECU, or to an expansion module, you must also configure it in order to make EVO4 record the proper data.

In particular, per every channel you have to define:

- The connected sensor
- The frequency acquisition of the sensor
- The unit of measure

Please use Aim software RaceStudio2 for system configuration.

RaceStudio2 Configuration.

In this chapter it is explained how to configure EVO4 with RaceStudio2 software.

Connect EVO4 to your PC and run RaceStudio2.

- > Select the button **"Device Configuration"**
- > Select **EVO4**.



You will see this screenshot:

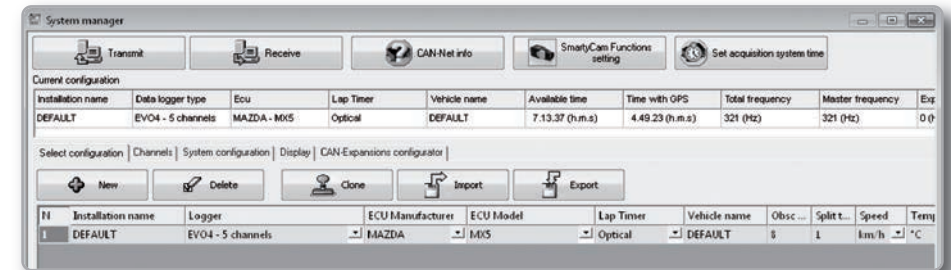

Press the **"New"** button and fill in the required fields.

You must now define the parameters of the system.

Each point will be explained in more depth in the dedicated chapter.



System Configuration.

In the following RaceStudio2 page you can set:

- How RPMs are acquired: from ECU data stream or reading a digital signal.
- The maximum rpm value.
- The division factor of the engine revolutions, ie the constant for which to divide the digital pulses number in order to obtain the correct value.
- How to get the gear number: by calculation, potentiometer or ECU.
- To use GPS in order to get lap time
- To select a speed signal as Reference Speed.
- How to manage digital output.

Channels Configuration.

In the following RaceStudio2 page you can define:

- Which channels are enabled.
- The type of sensor connected.
- The sampling frequency.
- The unit of measure.

Channel identifi.	Enabled/disabled	Channel name	Sampling frequ...	Sensor type	Measure unit	Low scale
RPM	<input type="checkbox"/> Disabled	Engine	10 Hz	Engine revolution speed	rpm	0
SPD_1	<input checked="" type="checkbox"/> Enabled	Speed1	10 Hz	Speed	km/h .1	0.0
SPD_2	<input checked="" type="checkbox"/> Enabled	Speed2	10 Hz	Speed	km/h .1	0.0
CH_1	<input checked="" type="checkbox"/> Enabled	Channel_1	10 Hz	Generic linear 0-5 V	V .1	0.0
CH_2	<input checked="" type="checkbox"/> Enabled	Channel_2	10 Hz	Generic linear 0-5 V	V .1	0.0
CH_3	<input checked="" type="checkbox"/> Enabled	Channel_3	10 Hz	Generic linear 0-5 V	V .1	0.0
CH_4	<input checked="" type="checkbox"/> Enabled	Channel_4	10 Hz	Generic linear 0-5 V	V .1	0.0
CH_5	<input checked="" type="checkbox"/> Enabled	Channel_5	10 Hz	Generic linear 0-5 V	V .1	0.0
CALC_GEAR	<input type="checkbox"/> Disabled	Calculated_Gear	10 Hz	Calculated Gear	#	0
ACC_1	<input checked="" type="checkbox"/> Enabled	Acc_Laterale	10 Hz	Lateral accelerometer	g .01	-3.00
ACC_2	<input checked="" type="checkbox"/> Enabled	Acc_Longitudinale	10 Hz	Longitudinal accelerometer	g .01	-3.00
ACC_3	<input checked="" type="checkbox"/> Enabled	Acc_Verticale	10 Hz	Vertical internal accelerometer	g .01	-3.00
LOG_TMP	<input checked="" type="checkbox"/> Enabled	Datalogger_Temp	10 Hz	Cold joint	°C	0
BATT	<input checked="" type="checkbox"/> Enabled	Battery	1 Hz	Battery	V .1	5.0
ECU_1	<input type="checkbox"/> Disabled	MIS_RPM	10 Hz	Engine speed sensor	rpm	0
ECU_5	<input checked="" type="checkbox"/> Enabled	MIS_SPD_FL	10 Hz	Speed sensor	km/h .1	0.0
ECU_6	<input checked="" type="checkbox"/> Enabled	MIS_SPD_FR	10 Hz	Speed sensor	km/h .1	0.0
ECU_7	<input checked="" type="checkbox"/> Enabled	MIS_SPD_RL	10 Hz	Speed sensor	km/h .1	0.0
ECU_8	<input checked="" type="checkbox"/> Enabled	MIS_SPD_RR	10 Hz	Speed sensor	km/h .1	0.0
ECU_9	<input checked="" type="checkbox"/> Enabled	MIS_BRAKE_PRESS	10 Hz	Raw value	# .01	0.00
ECU_10	<input checked="" type="checkbox"/> Enabled	MIS_BRAKE_SWITCH	10 Hz	Raw value	#	0
ECU_11	<input checked="" type="checkbox"/> Enabled	MIS_ABS_ALARM	10 Hz	Raw value	#	0
ECU_16	<input checked="" type="checkbox"/> Enabled	MIS_PPS	10 Hz	Percentage sensor	% .1	0.0
ECU_17	<input checked="" type="checkbox"/> Enabled	MIS_CLUTCH_SWITCH	10 Hz	Raw value	#	0

ECU Connections.

EVO4 can acquire data from all the ECU published on the list on our website: http://www.aim-sportline.com/pages/download/section_documentation_ecus.htm
This list includes about 500 different protocols and is constantly being updated, since all the ECUs are often improved and new models appear. When possible, we have explain how to configure your ECU to ensure compatibility between the data flow transmitted and what the protocol is designed to manage.

From the hardware point of view, EVO4 is compatible with all currently available connections: CAN, RS232 or line K. If you need a CAN or RS232 connection, you must connect the cable to the connector labeled "ECU"; if you have to use the OBDII K Line, please use the connector labeled "rpm / K".

The steps to manage the data coming from the ECU are:

- 1. Determine which hardware connection is available for your ECU.
If your ECU transmits the data to CAN or RS232, you need to connect the cable 04.563.01 (Shown below left) to the connector labeled ECU.
If it is equipped with a K line, you must use the cable 04.563.05 (shown below right) and connect to the connector labeled "rpm / K".



Please refer to drawings listed in the appendix for further information regarding these cables.

- 2. Please read the documentation about your ECU in www.aim-sportline.com, and identify the name of the proper software driver.
- 3. Configure EVO4 setting that software driver in RaceStudio2. (1)
- 4. Select the channels to be recorded.
- 5. Send the configuration to EVO4. (2)

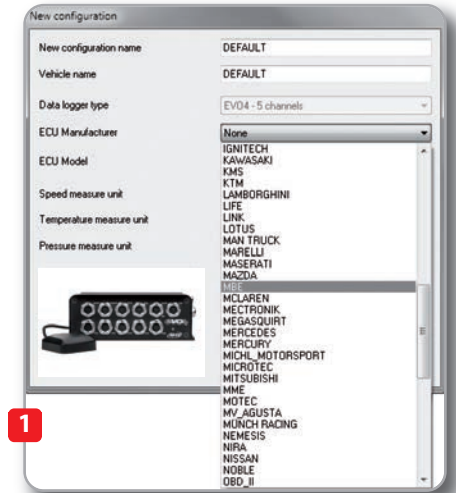

The RPM Channel.

EVO4 can get the RPM signal in many different ways:

- From ECU
- Through a square wave signal (8 to 50 V)
- From the low voltage (from 150 to 400V) of the coil.
- From the spark plug by converting the inductive RPM signal read from the spark plug into a square wave signal.
In this case you must use an optional RPM adapter **Code X10ADRP000.**

■ How to read RPM from ECU

To get RPM from the ECU, connect EVO4, configure it as shown in the previous paragraph and enable RPM acquisition from ECU.

In this case, RPM is of course just one of the many data flowing from your ECU to EVO4.

■ Acquiring the RPM via a 5-50 V square wave signal or coil (150-400 V)

In case your engine is not managed by any ECU, EVO4 can read the signal from the low voltage of the coil (whose peak can be from 150 to 400 V) or from a possible square wave (the peak can be from 5 at 50V.) The connector labeled "rpm / K", reported in Figure 13, receives the signals:

- Low coil voltage 150-400 V on Pin 1
- 4-50 V square wave on pin 3

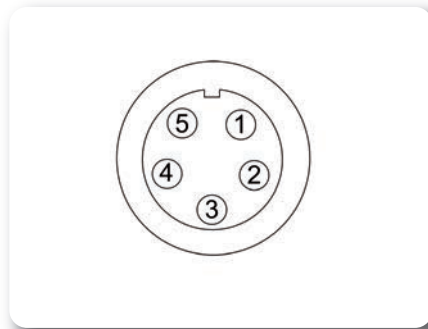

The connection cable is in the kit and its code is **04.563.02.**

You will find the technical drawing in the Appendix.

The following image shows an example of wiring for the ignition system. The output cable, labeled gray tach, which can be acquired directly from EVO4 through the 5-50 volts. input, is shown here:

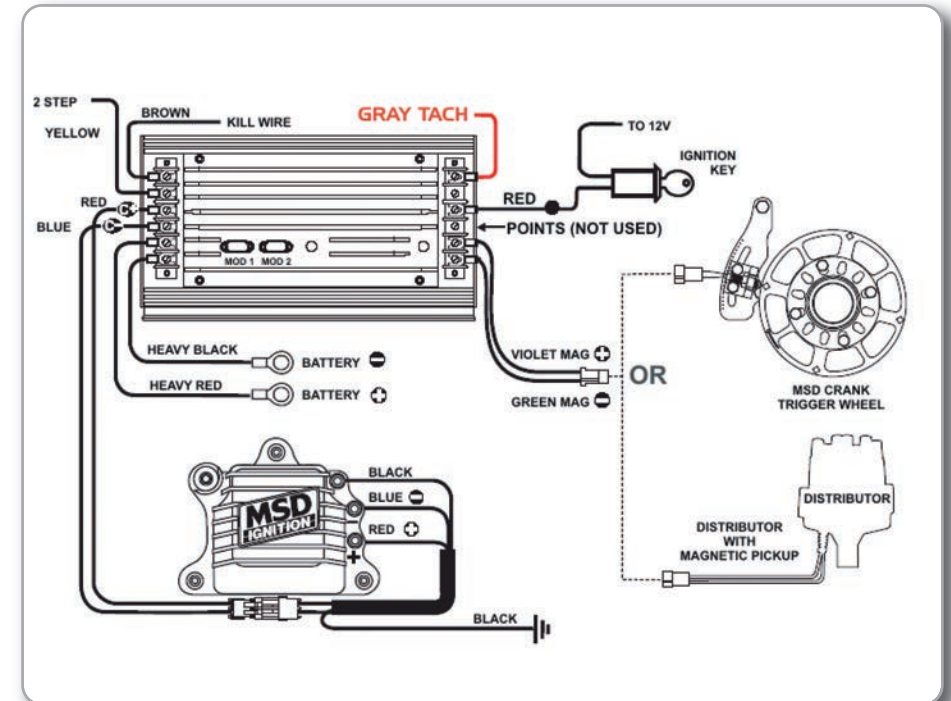

If an output is not available from the ignition system, the system has to be connected to the low voltage of the coil.

The coil from which to get the signal, is schematically shown in the image below.

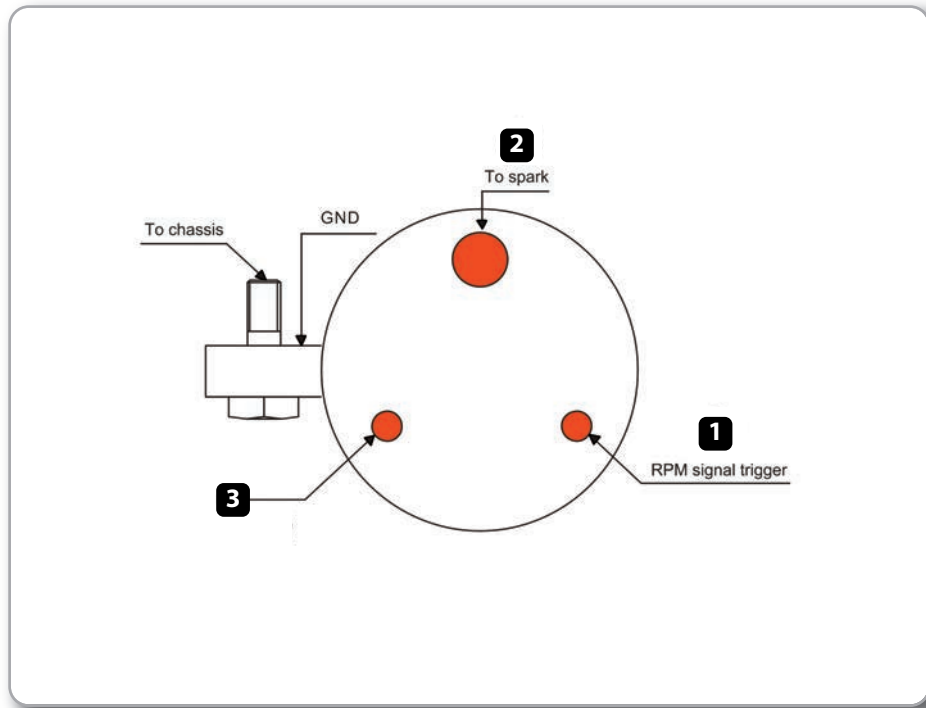

■ **Point 1**
Is the low voltage input of the coil.

■ **Point 2**
Is connected to the spark plug.

■ **Point 3**
Is connected to the positive pole of the battery (+12 V).

Shows an example of connection between coil and spark plug.

The voltage at the points indicated by the numbers 1, 2 and 3 is shown.

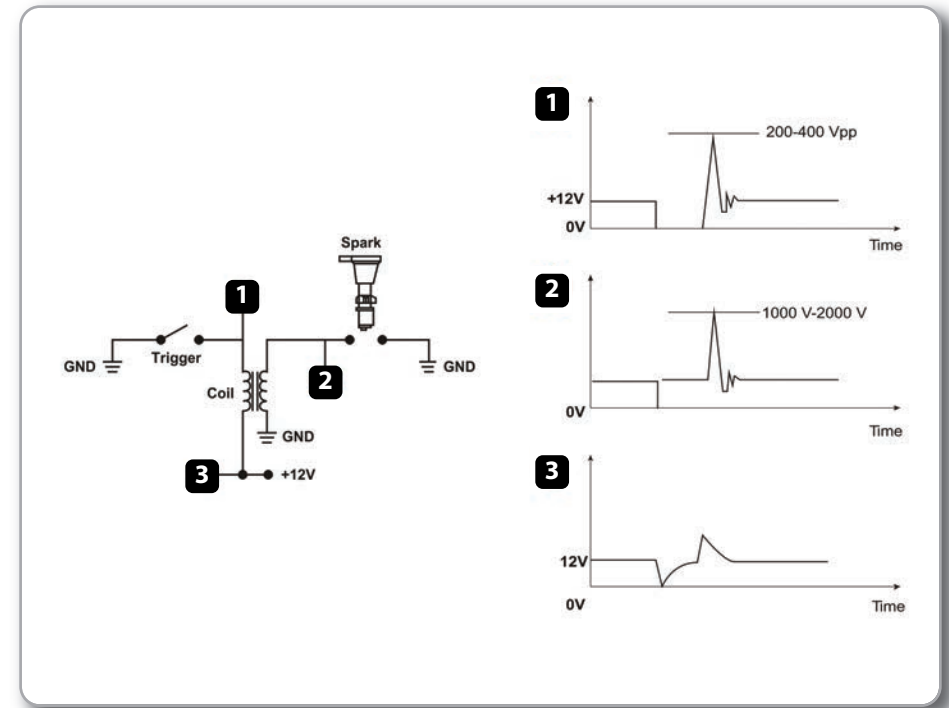

In order to properly configure EVO4 using the control panel you must:

- Ensure AIM sensor is selected.
- Define "max RPM."
- Select the possible multiplication factor (RPM factor).

Its value is typically 1 for two-stroke engines and four-stroke multi-cylinder, and 2 for single-cylinder four-stroke engines.

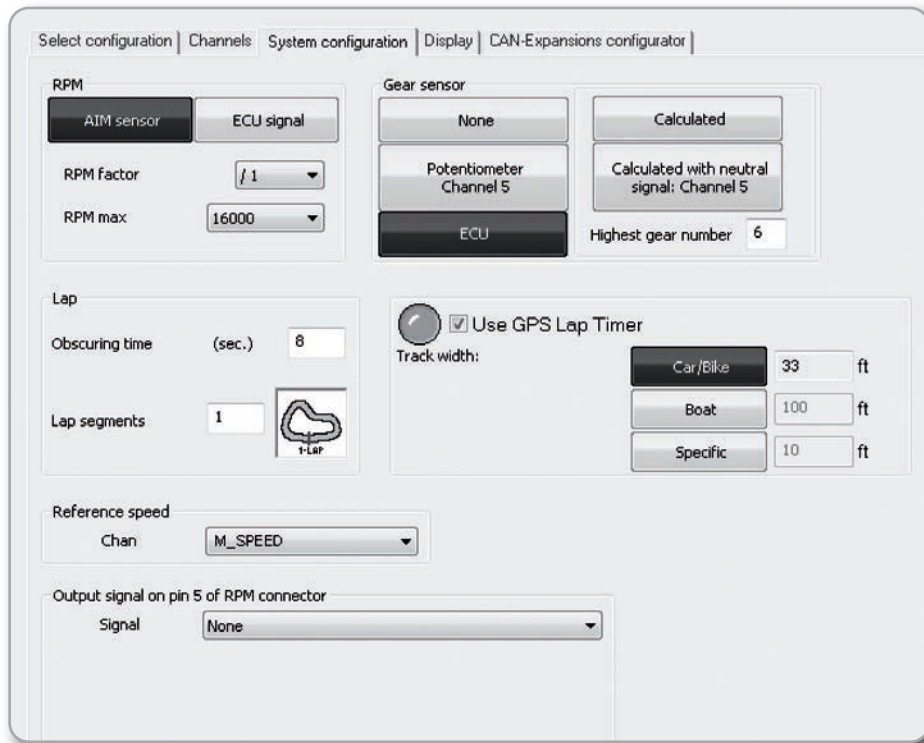

■ When the RPM signal is noisy

Sometimes the signal from a low voltage point 0-50 V of the coil is particularly noisy and EVO4 does not read RPM properly, as in the examples:

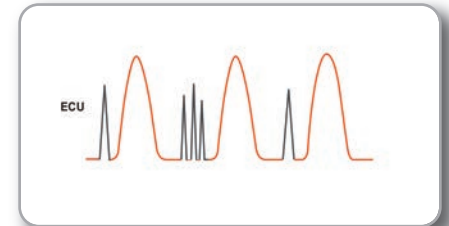

Dirty signal from the ECU



Dirty signal from the coil

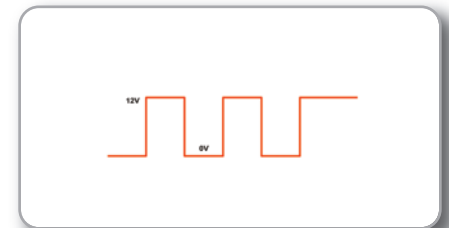

Filtered wave signal

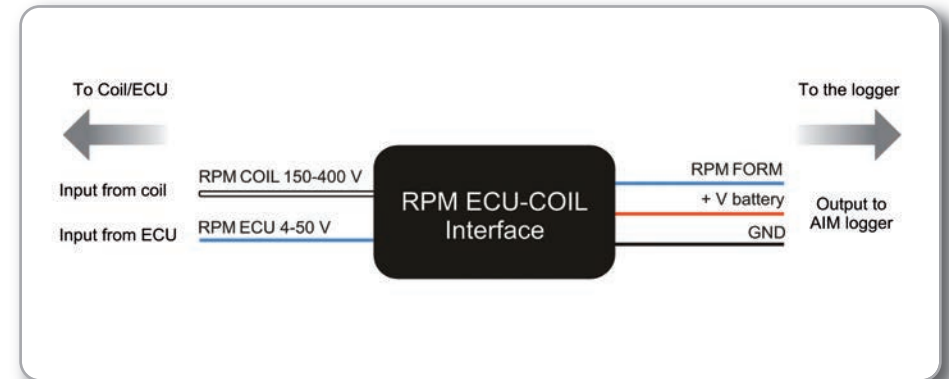

In such cases, the filter shown in Fig.17 (**Code X05ADRPMM30**) can be useful. The input of the filter must be connected to the signal RPM, and the output to the input square wave EVO4 for 5-50 V (pin 3 of connector rpm / K).

The Speed Channel.

EVO4 can receive the speed signal from three different sources:

- The ECU
- The Built - in GPS receiver
- The two digital channels

It is possible that EVO4 receive and store different values of speed at the same time: the more powerful ECUs transmit up to four wheel speed values; considering speed values that come from GPS and from the two digital channels, there may be 7 different speed values.

*Note that even if EVO4 can read and record up to seven values of speed, only ONE of these is used for some special functions, such as:

- **Gear calculation**
- **Distance measurement**
- **Data visualization in analysis software**

This speed is called **"Reference Speed"** and is defined in the software RaceStudio2.

■ Speed read from ECU

If your ECU sends the value of speed in its data stream, it is possible to read, record and show that information. Simply enable the channel in RaceStudio2 and set define this speed as **"Reference Speed."**

■ Speed read from GPS receiver

The GPS receiver integrated in EVO4 is configured in order to obtain the best performance in terms of reactivity and accuracy. We know that GPS signals are extremely weak, only 20 watts, and are transmitted from satellites at 20.000 km away. Data accuracy can therefore sometimes be not as good as we would like. However, we can say that it is generally more than satisfactory and that GPS speed is very often better than wheel speed.

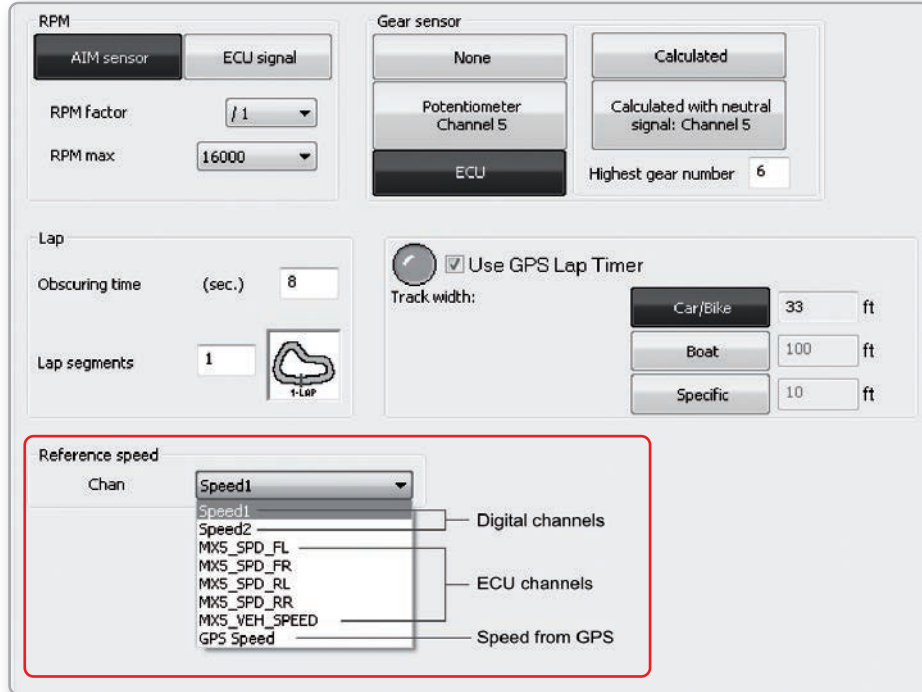

■ Speed read from the wheel

EVO4 has two wheel speed inputs, in the same "speed" connector:



The digital sensor **X05SNBS00** detects the presence of a metallic tooth placed at a distance between 0.5 and 2 mm.



If you wish to acquire two speed inputs, you must use the cable **code: 04.563.02**.



■ For configuring wheel speed parameters.

Enter the Program Configuration panel and after enabling the channel desired speed (speed 1, speed 2 or both), set the wheel circumference and the number of pulses per revolution:

Select configuration | Channels | System configuration | Display | CAN-Expansions configurator

Speed1

1 Wheel circumference (mm) 65.59

Pulses per wheel revolution 1

Speed2

Wheel circumference (mm) 65.59 2

Pulses per wheel revolution 1

Channel identif...	Enabled/disabled	Channel name	Sampling
RPM	<input type="checkbox"/> Disabled	Engine	10 Hz
SPD_1	<input checked="" type="checkbox"/> Enabled 3	Speed1	10 Hz
SPD_2	<input checked="" type="checkbox"/> Enabled	Speed2	10 Hz
CH_1	<input checked="" type="checkbox"/> Enabled	Channel_1	10 Hz

Analog Inputs.

EVO4 has five 12 bits analog inputs, recorded up to 1000 times per second each.

You can connect 0-5 Volt signals, ratiometric potentiometers, pressure sensors, thermo-resistances and K-type thermocouples.

Please, follow the steps:

1

Connect the sensor to the desired input

2

Enable the channel in the Channels table

3

Select the proper sensor type; sensors of many different types are properly handled, such as: Temperature sensors, Pressure Sensors, Potentiometers, Generic Sensors.

4

Set the sampling frequency

5

Set the unit of measure.

■ Temperature sensors

K thermocouples
Thermo-PT100 resistors
Temperature sensors VDO

■ Pressure Sensors

VDO 40-120 °C
VDO 50-150 °C
VDO 60-200 °C
MSI 0-2 bar
MSI 0-5 bar
MSI 0-10 bar
MSI 0-2000 psi

■ Potentiometers

Distance
Zero-based
Zero Central

■ Generic Sensors

0-50 mV
0-500
0-5 V

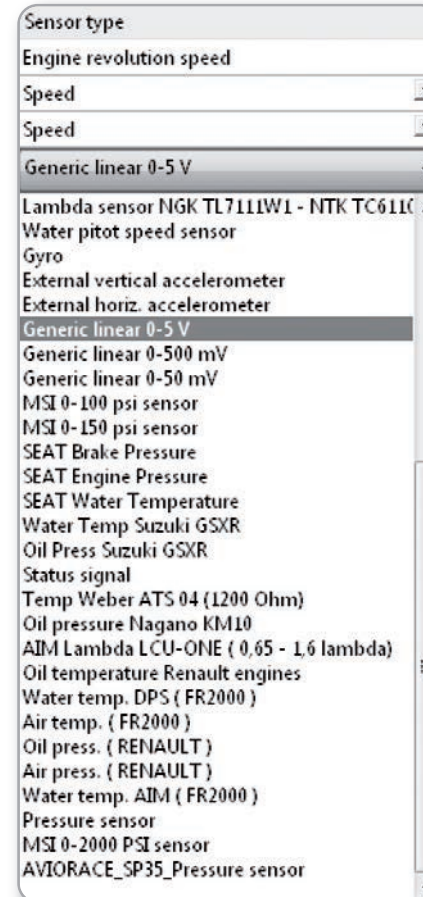

A triaxial accelerometer is to be properly configured. When selected, the following screen appears:

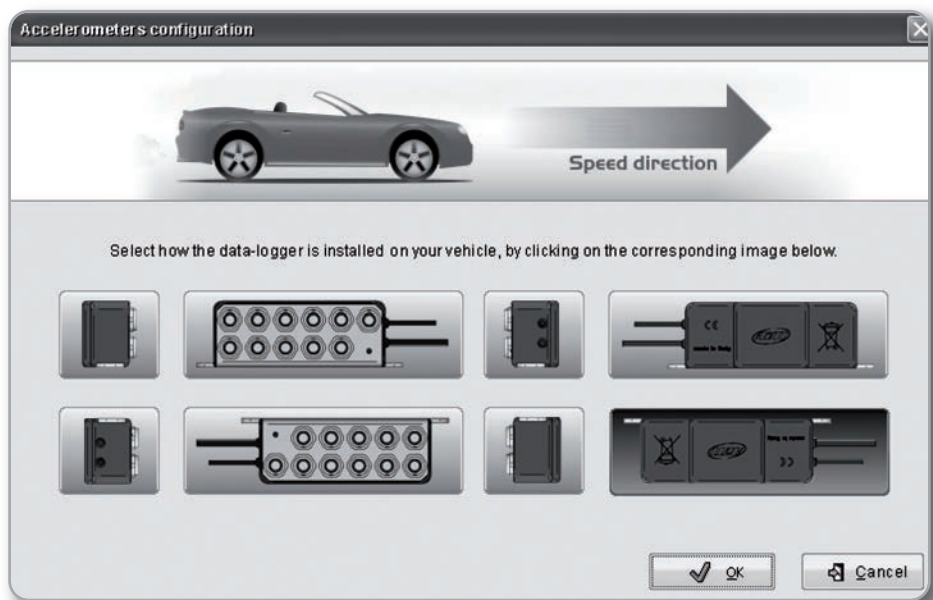

On this screen you can define the direction of installation EVO4. Simply select the image consistent with your installation. The three signals from the accelerometer are automatically related to the proper directions.

After having transmitted the configuration to EVO4, you must calibrate the sensor by pressing the button "Transmit".

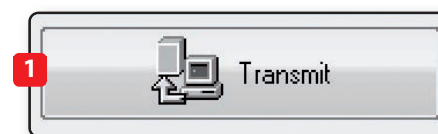

The calibration is used to define the range of some sensors such as potentiometers and accelerometers.

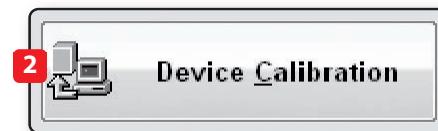

GPS.

The integrated GPS in EVO4 provides the following information, updated ten times per second:

- Position (latitude, longitude, altitude)
- Speed
- Longitudinal acceleration
- Latitudinal acceleration

In the case EVO4 knows the finish line of the track and split coordinates, it can also calculate:

- Lap times
- Split times
- Test length

To transmit track information to EVO4, use GPSManager software, as explained in the dedicated chapter.



■ How to configure

In order to use GPS data to compute lap times and split times, you have to:

- Properly configure EVO4.
- Transmit EVO4 the coordinates of the finish line and split lines.

To configure EVO4, access the **“Setup Menu”** and set **“GPS Lap Timer”**:(1)

You can set Finish and Split line coordinates in two different ways:

- Use the software GPS Manager to transmit information relating to the tracks where you are going to drive. EVO4 will automatically recognize the track and will use the proper coordinates.
- Set the finish line coordinate directly on the track. This can be done only if EVO4 is connected to a dash.

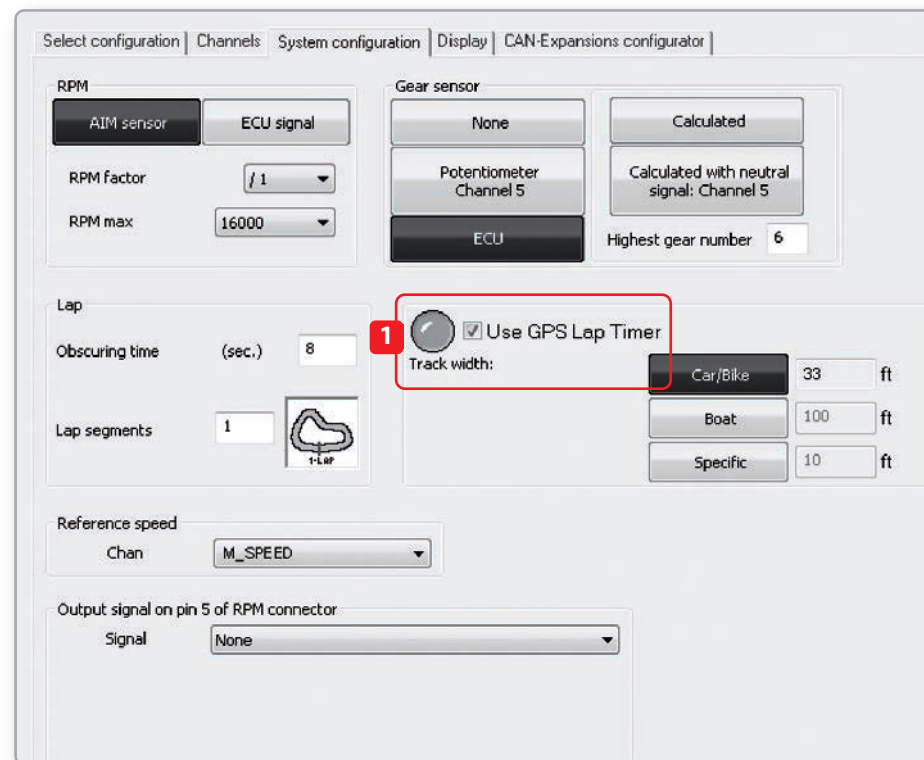

GPS Manager Software.

By GPS Manager you can update, modify, transmit and receive to and from EVO4 the coordinates of finish line and split points of all the tracks where you are going to run.

When opening the software, if there is no system connected to your PC via USB cable, you will see the screen shown.

As you can see, the screen is divided into two parts. On the left you see the track list, split in dependence of the countries of origin.

If available, you will see the track layout and the type of vehicle that usually race on the track: car, motorcycle or kart.

On the right side of the screen, you will find a big picture of the track.

- 1 Track management command
- 2 Selection window for dynamic filters
- 3 Track type: car, bike, karts
- 4 Track data manager
- 5 Track shape, with starting line and split points position
- 6 Small track shape
- 7 Track selection
- 8 Open/Close Country track data

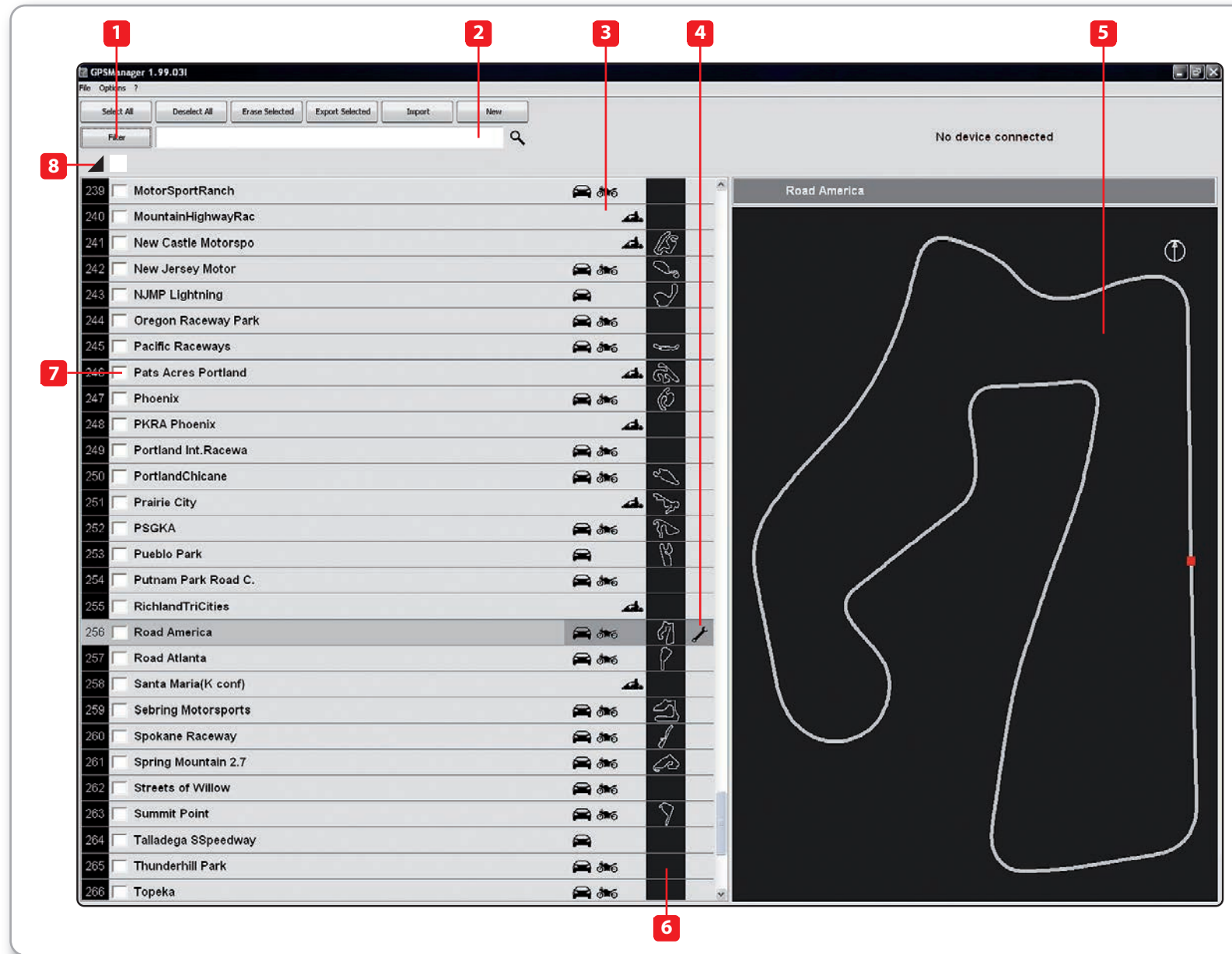

Filters in track data base management.

In order to only see tracks you need, you can filter the list of tracks in different ways.

The filters can be static, (1) that is to say, are recorded and used every time you use GPSTracker, or dynamic, (2) that are not saved when quitting the program.

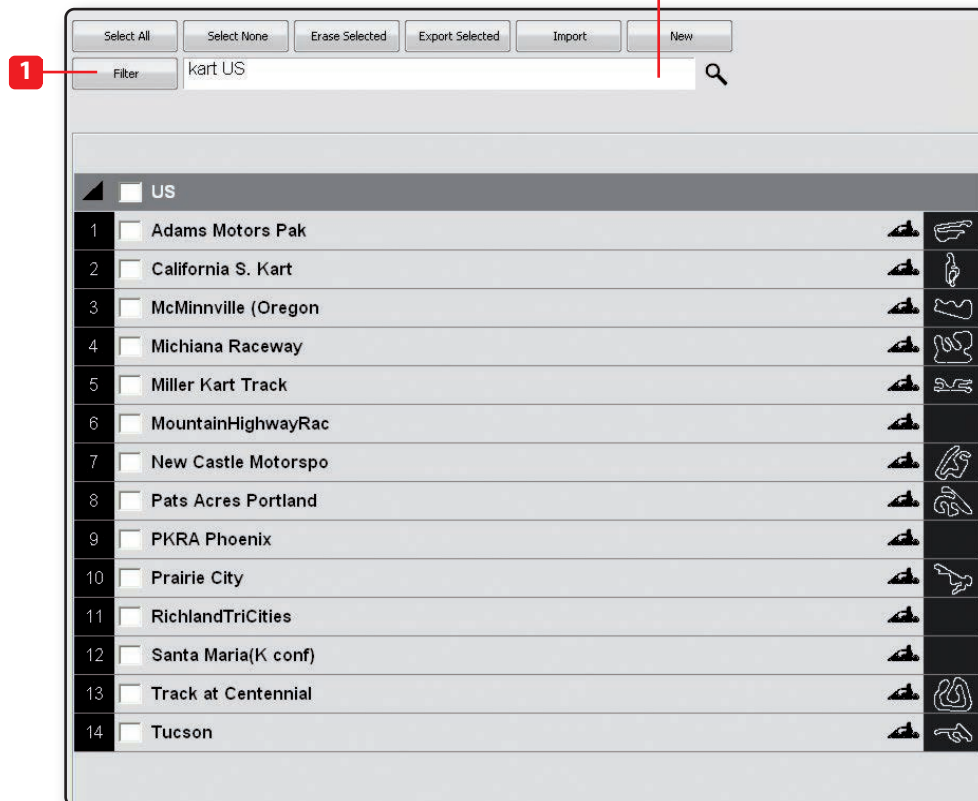

■ Static Filters.

A static filter is activated by the button below. The window shown will appear.



It will allow you to select nations, the type of vehicle and type of circuit.

The lists show only countries, vehicles and types of circuit present at least once in the database.

For example, if you have not used any track in Germany, this country will not appear in the list.

By default all countries, types of vehicle and tracks are abilited.

If you are interested in only the car tracks, for example, you must disable karts and motorcycles.

■ Dynamic Filters.

The Dynamic filters are activated in the box at the top left of the screen:

The dynamic filters allow you to further filter the tracks (in fact the car) merging different characteristics.

For example, writing "Spain closed," you will see only closed circuits for cars in Spain.

How to add a new track to the PC database.

To add a new track

1) Press the button **"New"**

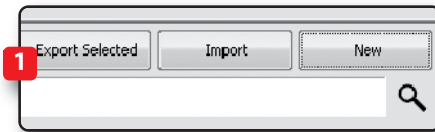

2) Enter the name of the track.

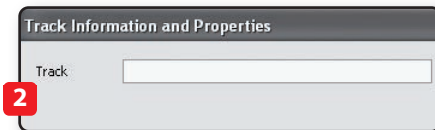

3) Enter the required information: Country, Type of circuit (**Closed**, **Oval** or **Open**) (**asphalt**, **dirt**, **ice**, **water**).

Finally, using the icon buttons, set the type of vehicle that usually run on the circuit: **Cars**, **Motorcycles** or **Karts**.

If you have already run a test on the track and have downloaded data, you can associate the shape of the track, pressing the **"Load Track"** button.

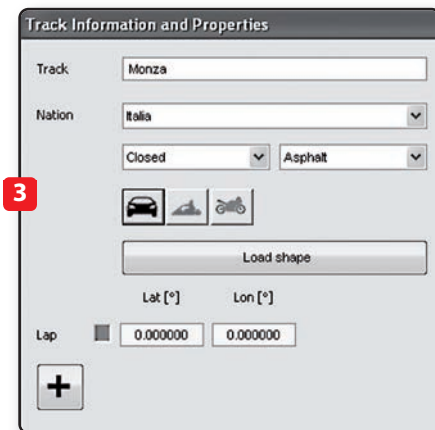

You can now select the file **".GPK"**, containing the coordinates of all the points of your test.

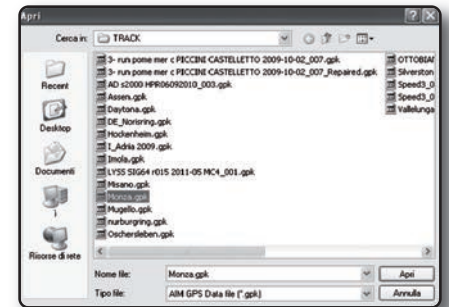

The shape of the track appears, splitted in different laps of the test. It is possible to scroll through the different laps, to zoom, to rotate the drawing.

After having selected the desired lap, push **"OK"** for saving the image of that lap. That image will be used as a reference shape for the future. Finish line coordinates are read from the **".GPK"** file but can be modified as desired in one of the following ways:

Define the coordinate by hand (1)

Position the cursor on the desired point of the track and click the pushbutton "Cursor Pos" (2)

In case of a Point to Point track, it is obviously useful to define the coordinates of the starting and finish line.

Push **"OK"** for saving the configuration.

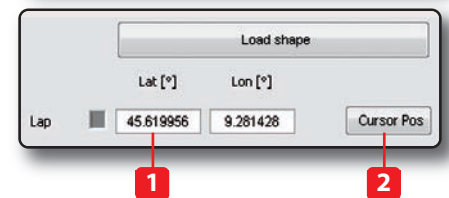

How to modify track data in the PC database.

Click the icon. The window containing the data of the track you can edit at will.

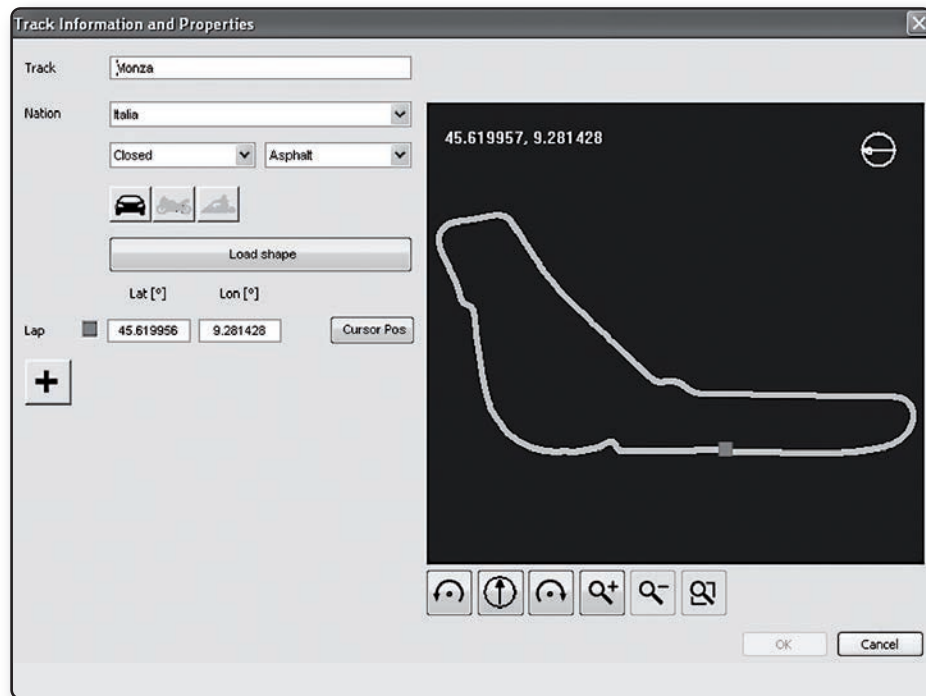
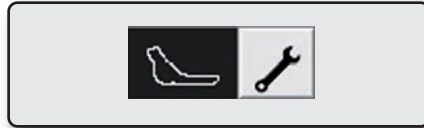

How to read, write and delete tracks information in EVO4.

Connect your system to your PC using the USB cable.

EVO4 manages only the name of the tracks and coordinates of the finish and split points, but not their country or the shape.

The GPS Manager screen will display two lists: on the left, the tracks in your PC and on the right, the tracks in EVO4.

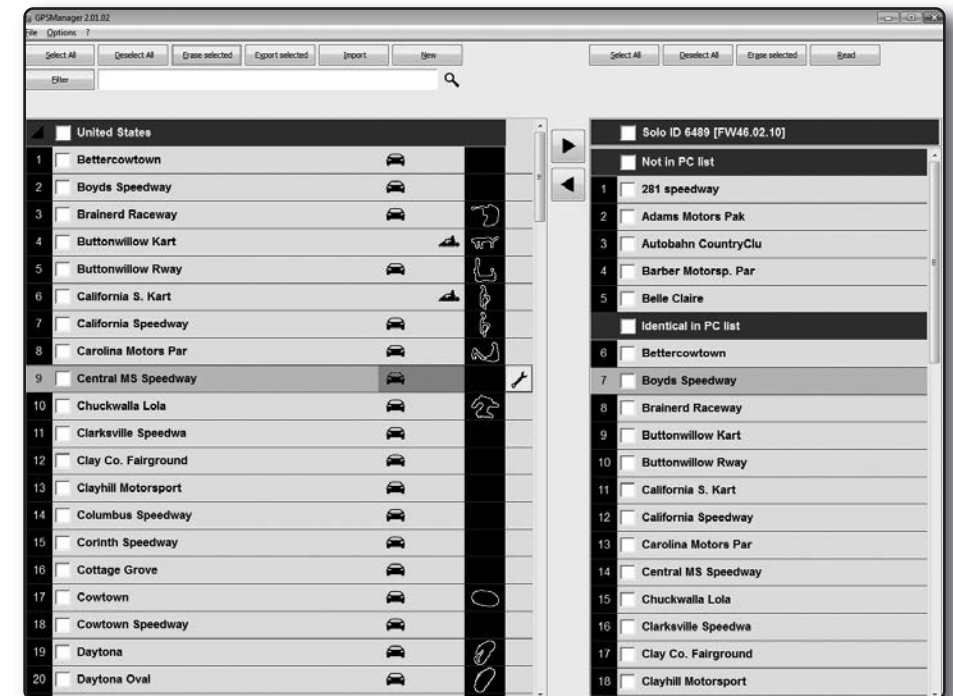

■ To transmit track information to EVO4

Select tracks to be submitted by clicking on the square check, or double-click on the name of the track.

■ To receive track information from EVO4

Select tracks to be submitted by clicking on the square check, or double-click on the name of the track

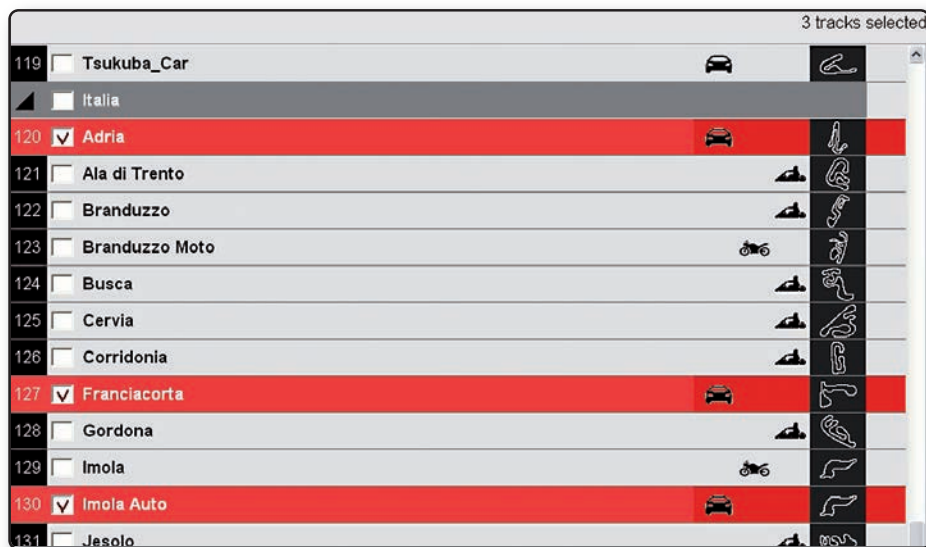

1



2

■ Drag in the right panel or press the button ►.

■ The tracks' information are updated in EVO4 panel.

■ Drag in the left panel or press the ◀ button.

■ Tracks' information are updated in the PC list.

■ To erase a track's information from EVO4.

Select the track to be erased in the right panel and press "Delete Sel".

■ To modify track's information in EVO4

You can only change a track name in the EVO4 track list.

To do this, double click on it. A window will appear containing the name ready for editing.

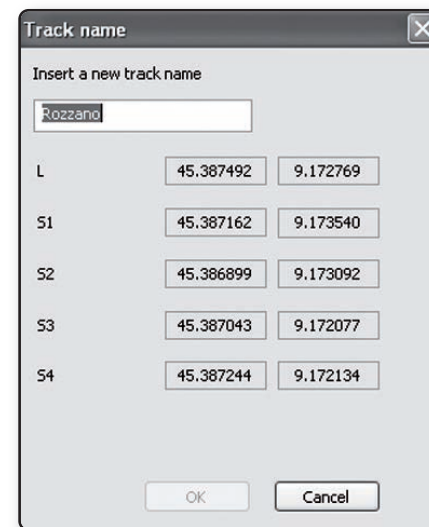

Pinout EVO4.

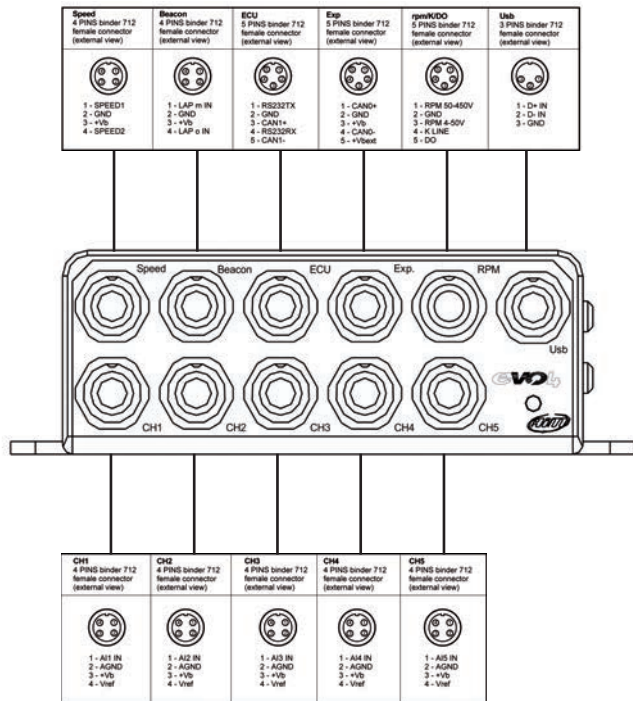

USB Cable for EVO4.

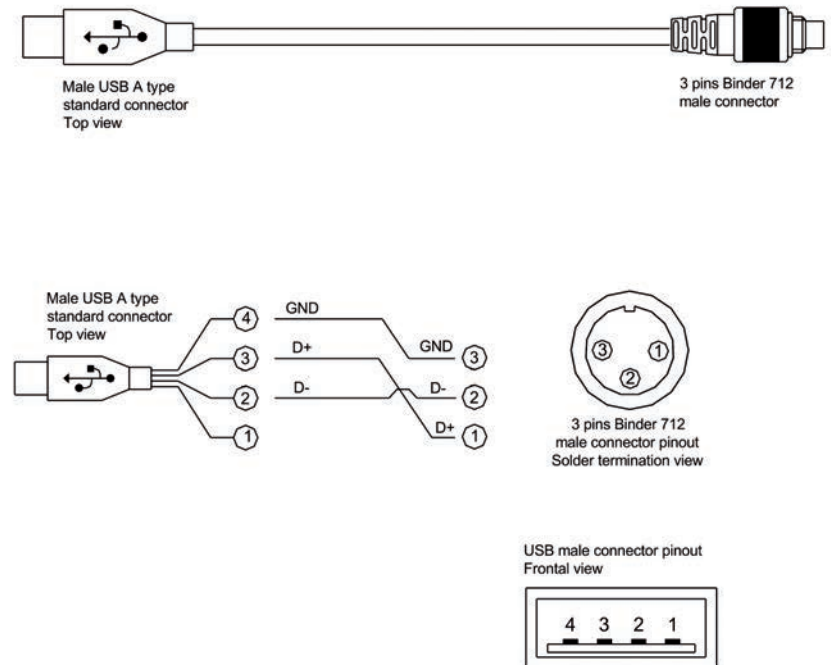

RPM, Gear flash and K Line cable for EVO4.

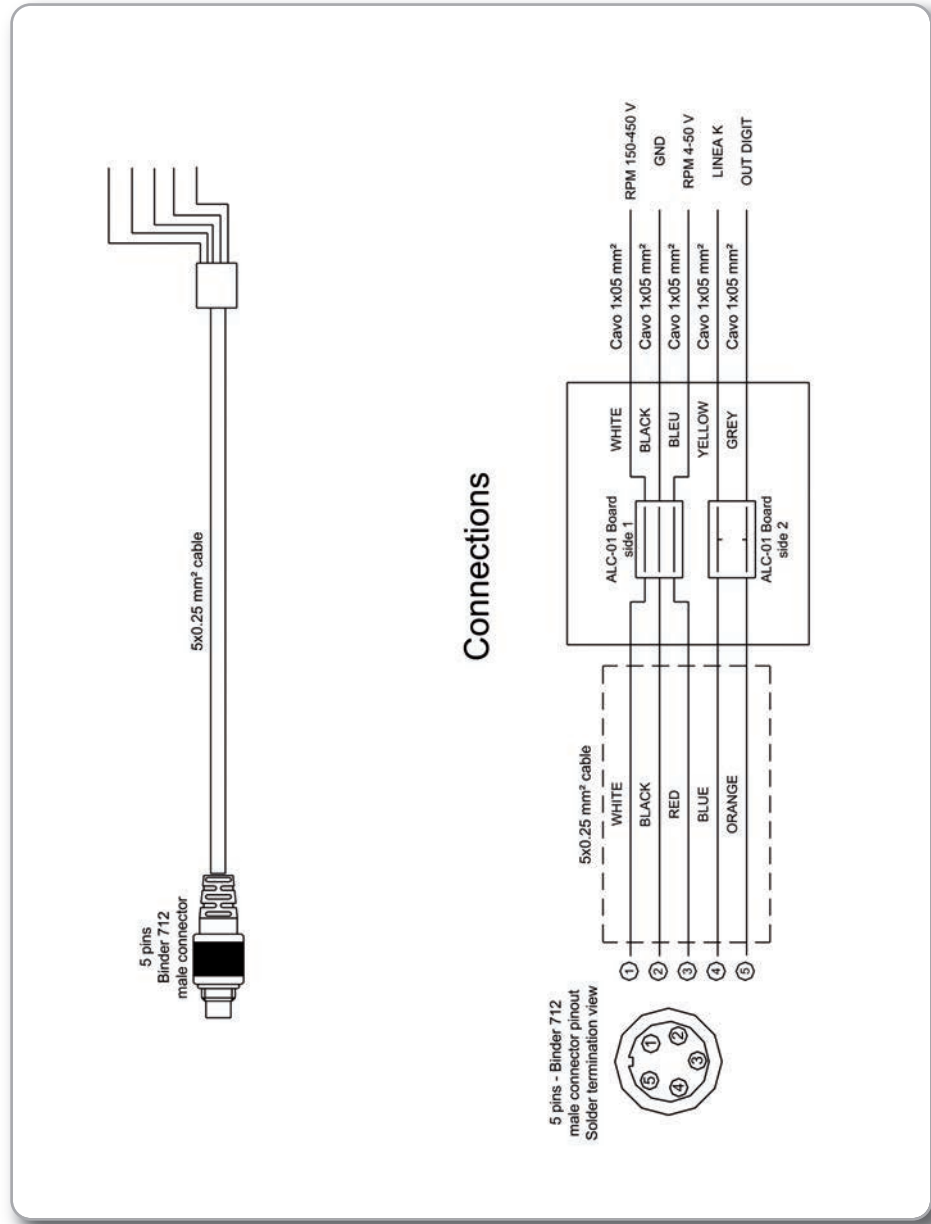

EVO4 CAN and serial ECU connection cable.

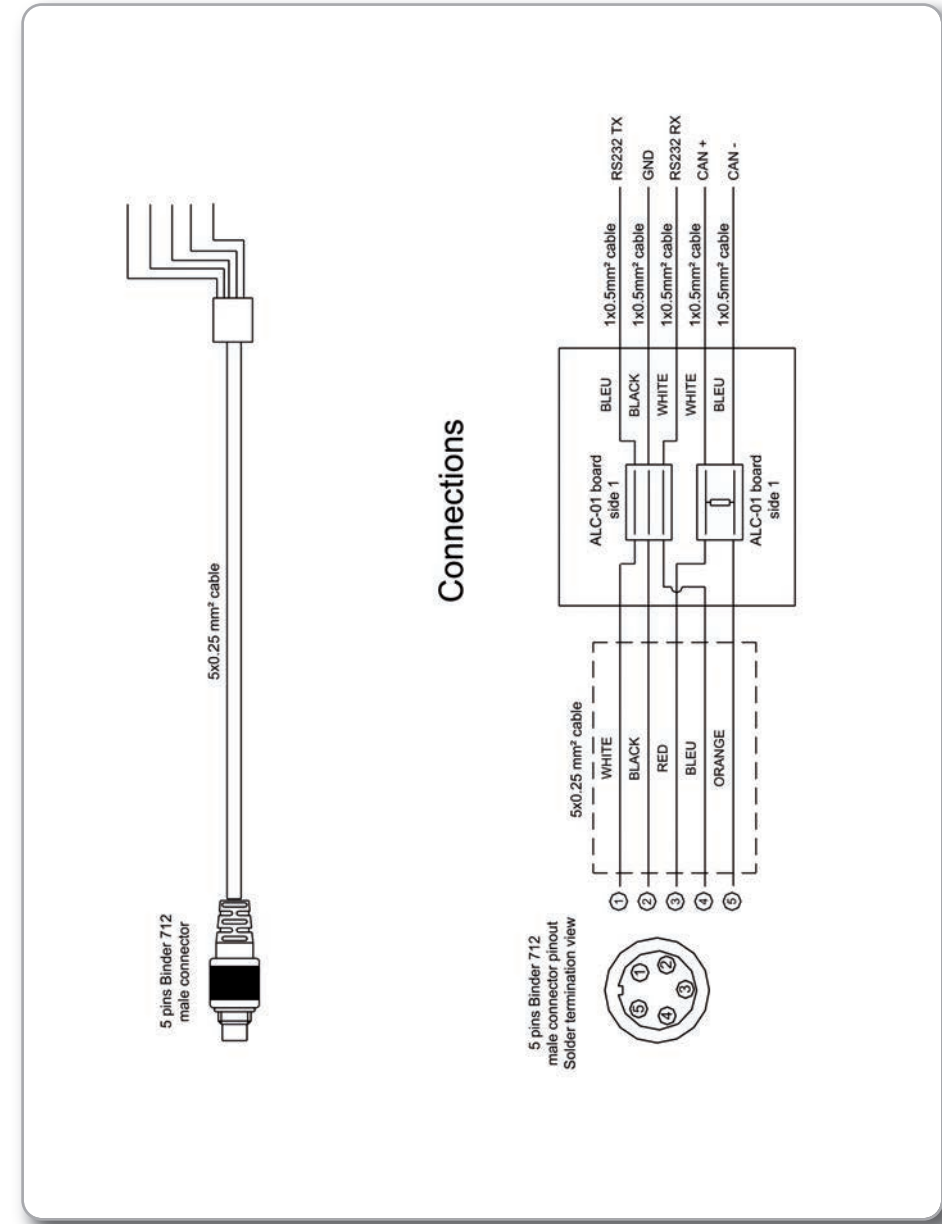

EVO4 K and L line cable with OBDII connection.

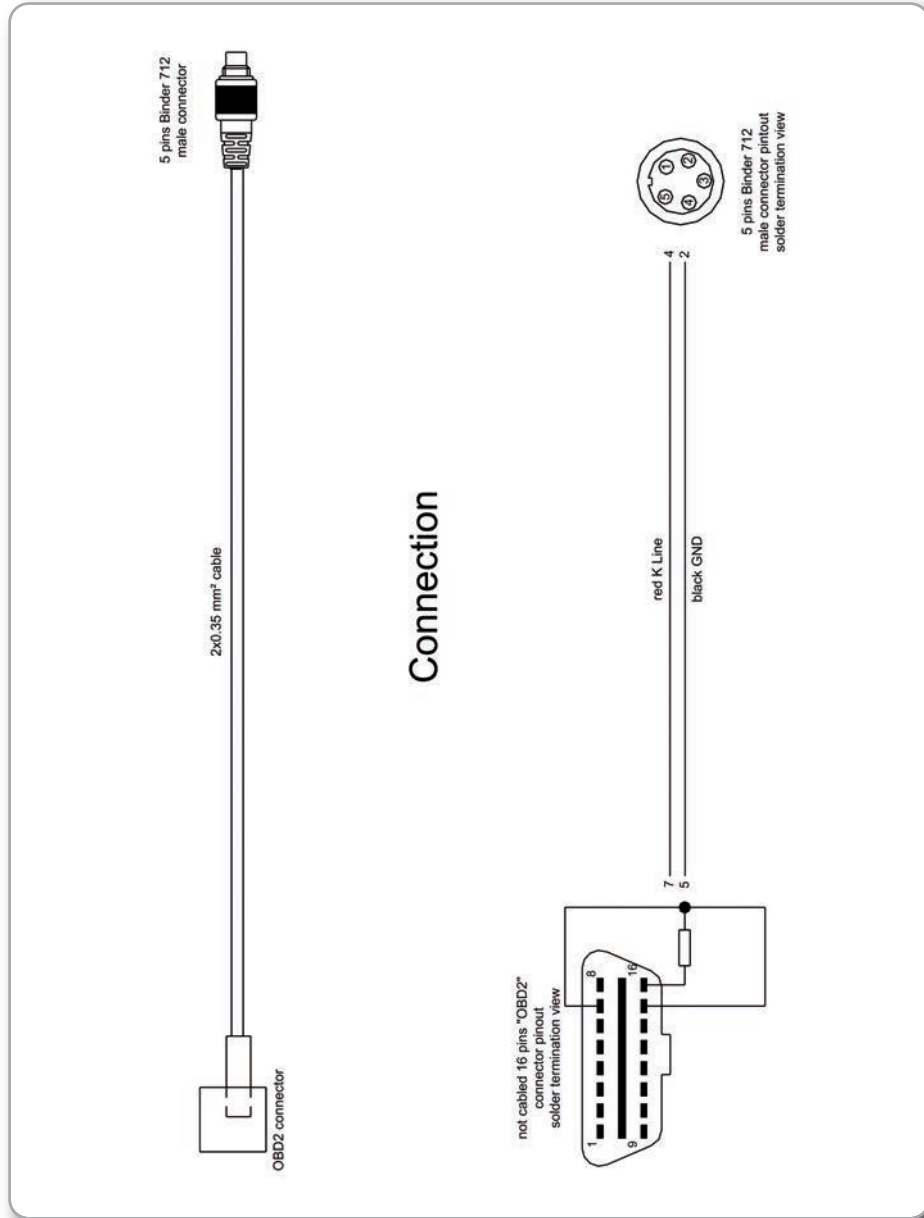

EVO4 CAN cable with OBDII connection.

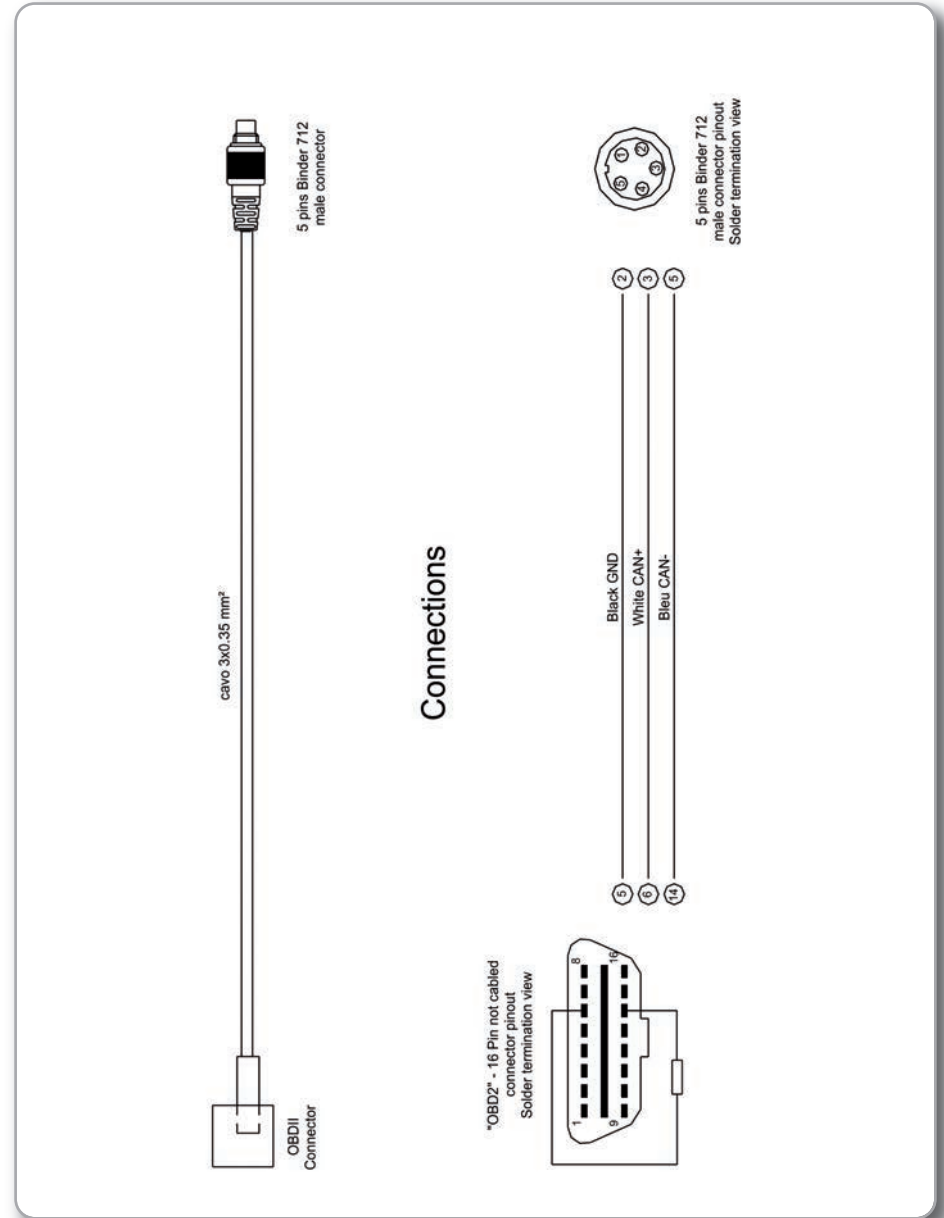

EVO4

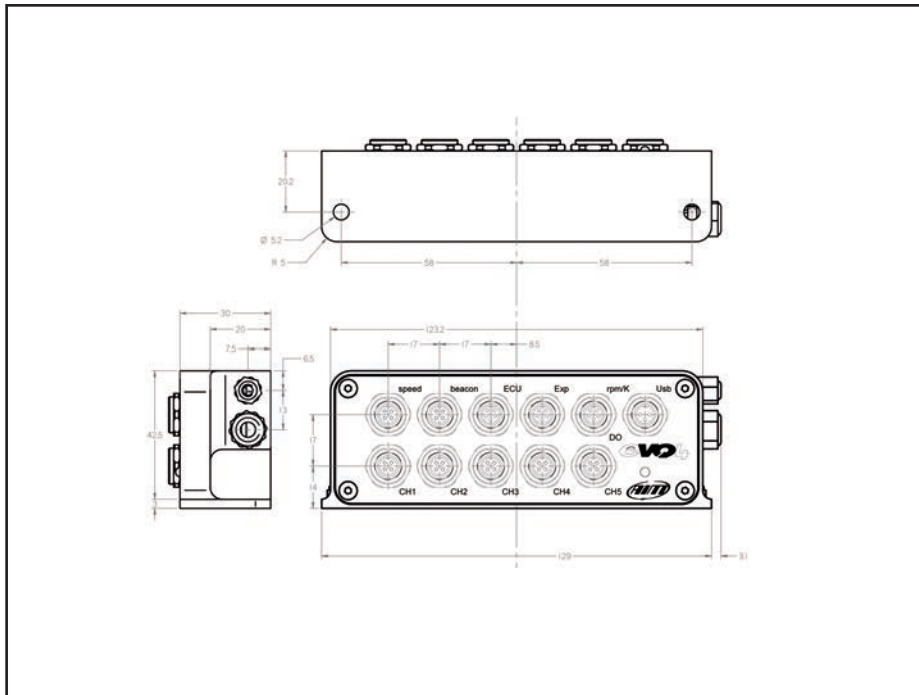

- 5 fully configurable analog channels
 - 2 speed channels
 - 1 digital RPM channel
 - 1 tri-axial internal accelerometer
 - Integrated GPS module
 - Laptime
(magnetic/optical lap and GPS lap)
 - CAN protocol for external expansion modules
 - ECU Interface
 - 5 KHz total sampling frequency
 - USB cable for data download
 - Memory: 16 Mb
 - External power: 9-15 V
 - Power consumption:
80-100 mA at 12V
-
- Dimensions: 123 x 30 x 42,5 mm
 - Weight: 260g
 - Waterproof IP67



Our web site aim-sportline.com is constantly updated.

We try to share with you our experiences about our products and how to use them in the tracks all over the world.

Please, constantly check it and download the last versions of the firmware of your products.

